

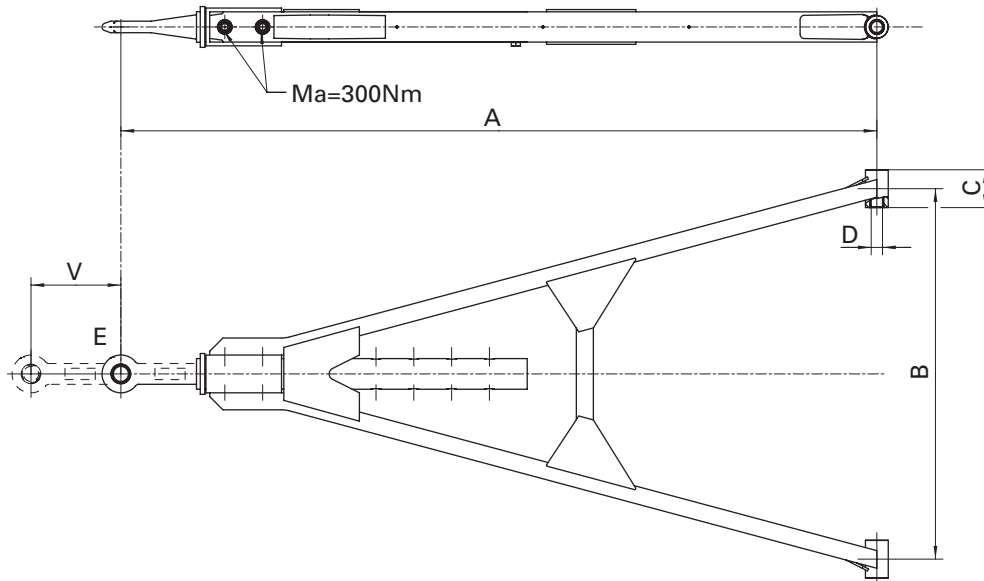



GZU

- DE** Zuggabel längenverstellbar, leichte Ausführung
- EN** Drawbar extendable, light weight design
- FR** Flèche de remorque réglable en longueur, exécution légère
- IT** Timone regolabile in lunghezza, modello leggero
- ES** Lanza-timón extensible, modelo ligero



												
		(t)	(t)	D (kN)	ECE	A (mm)	B (mm)	C (mm)	D (mm)	E	V (mm)	
YH	GZU 27*	27	9	125	E1 55R-01 2446	1200-1350	320-1400	60-100	24-50	1,3,4,5,6,	6x100	U 80
YH	GZU 27*	27	10	125	E1 55R-01 2446	1400-1850	320-1400	60-100	24-50	1,3,4,5,6,	6x100	U 80
YH	GZU 27*	27	10	125	E1 55R-01 2446	1900-2600	320-1400	60-100	24-50	1,3,4,5,6,	6x100 (8x100)	U 80
YJ	GZU 40 A	30	9	125	E1 55R-02 3311	1200-1350	320-1400	70-100	26-50	1,4,6	6x100	U 100
YJ	GZU 40 A	30	10	125	E1 55R-02 3311	1400-1850	320-1400	70-100	26-50	1,4,6	6x100	U 100
YJ	GZU 40 A	30	10	125	E1 55R-02 3311	1900-2600	320-1400	70-100	26-50	1,4,6	6x100 (8x100)	U 100
YK	GZU 40 B	30	9	190	E1 55R-02 3321	1200-1350	320-1400	70-100	26-50	3,5	6x100	U 100
YK	GZU 40 B	30	10	190	E1 55R-02 3321	1400-1850	320-1400	70-100	26-50	3,5	6x100	U 100
YK	GZU 40 B	30	10	190	E1 55R-02 3321	1900-2600	320-1400	70-100	26-50	3,5	6x100 (8x100)	U 100
YK	GZU 40 B	36	12	190	E1 55R-02 3321	2000-2600	320-1400	70-100	26-50	3,5	6x100	U 100

* Nicht geeignet für Forst- u. Baustellenfahrzeuge. • Not suitable for forestry and construction vehicles. • Ne convient pas aux véhicules d'exploitation forestière ou engins de chantier • Inadatto all'impiego in cantieri e nell'economia boschiva. • No es apto para vehículos forestales y de la construcción.